

CNC TURNING LATHE

VT-21

VT-23

SUPERIOR CUTTING

- ▶ 8 or 10-inch Chuck
- ▶ BMT Live Turret
- ▶ Box Ways



VIPER



*Fast
Set-up and
High Precision
Cutting*

VT-SERIES

21

23

FORTEX

www.alex-tech.com

Superior Cutting

Performance and Better Surface Quality

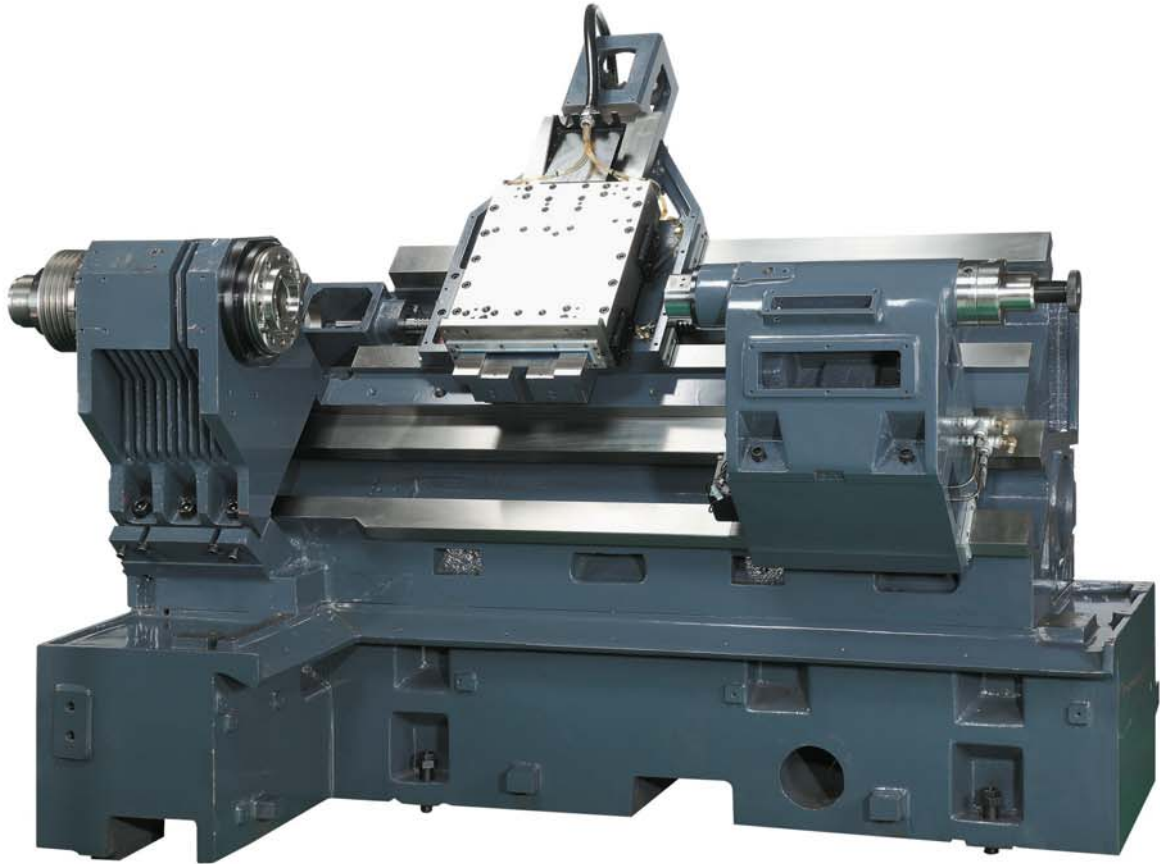

SOLID CONSTRUCTION

Rigid, one-piece Meehanite cast-iron-bed. Viper turning center construction provides the ultimate in machine tool accuracy and reliability.

A 45° slant bed design for our **VT-21/23** gives Viper its exceptional cutting stability facilitating optimal chip removal. Cutting reaction forces are minimized resulting in a high degree of precision. Both X and Y axes on Viper turning centers are supported by oversized hardened

and ground box type ways which facilitates exceptionally fast cutting rates.

PERFORMANCE FEATURES

- BMT-55 Live Turret*
- Sub-Spindle
- Spindle Motor 20 hp / 35 hp*
- Fully Conventional Programming

*Optional accessory.

TORQUE CHARTS

VT-21/23

Torque Chart

Spindle Motor: 20 hp

30 Min. Rating = (- -)

Continuous Rating = (- - -)

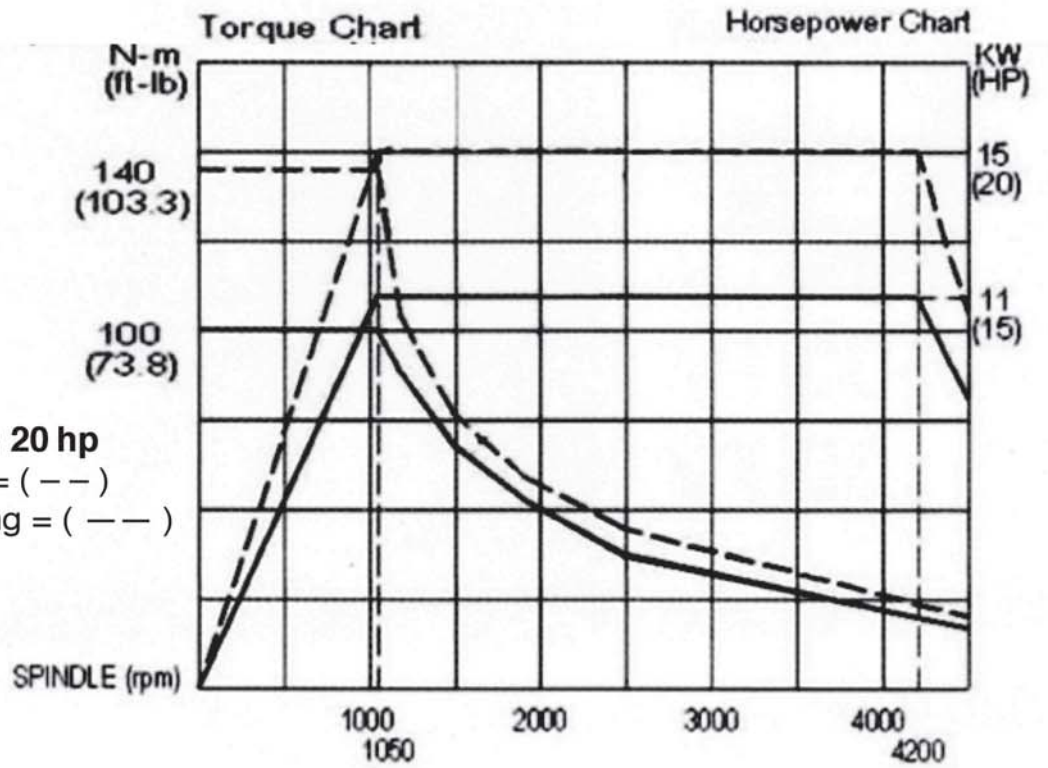

VT-21/23

Torque Chart

(option)

Spindle Motor: 35

30 Min. Rating = (- -)

Continuous Rating = (- - -)

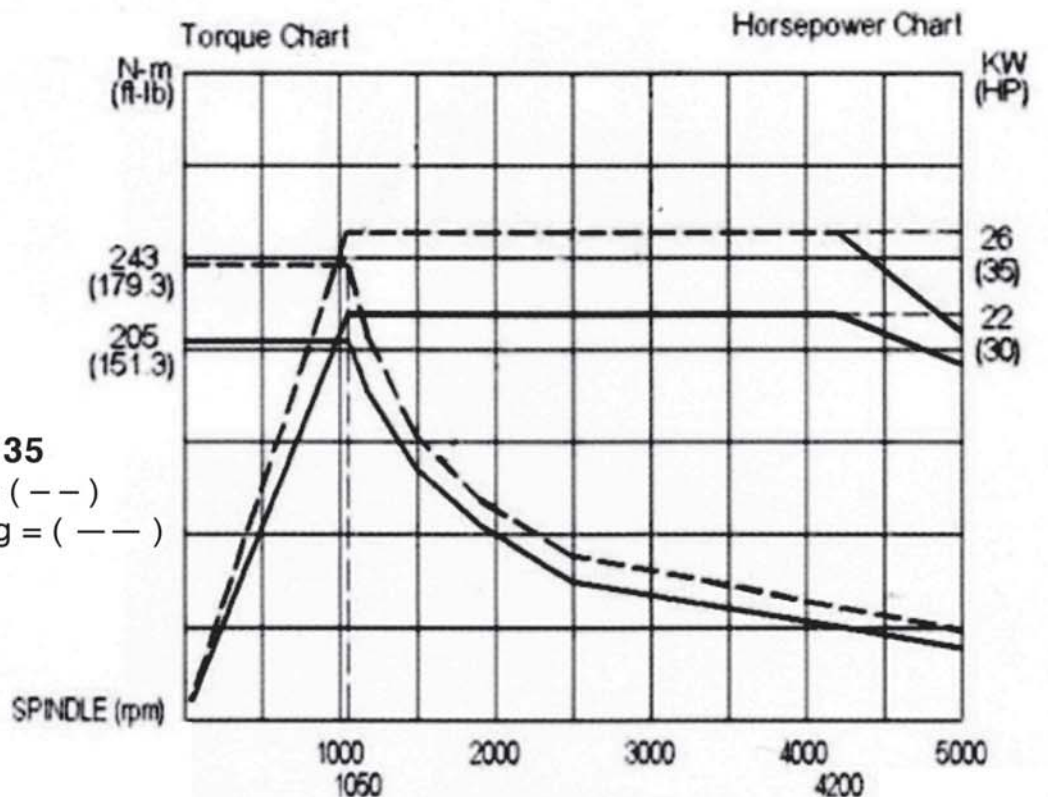

Turret Tool Holder

Bolt-On Mounting Tool (BMT)

- 4-bolt fitting system to maximize cutting rigidity.
- Turret holder rotates
- Keyways reference system to increase accuracy.
- Oversized tenon coupling to grant high torque power transmission.
- High precision preloaded spindle bearings.
- Advanced sealing system.
- Suitable for quick tool-change systems.

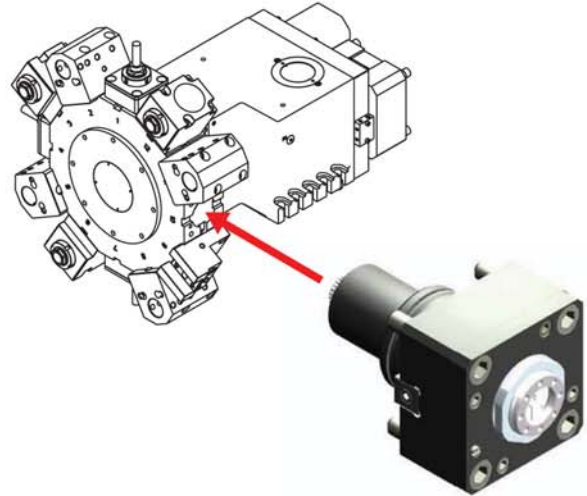

VT-21 and VT-23 use BMT-55 shank size.

TURRET TOOLING

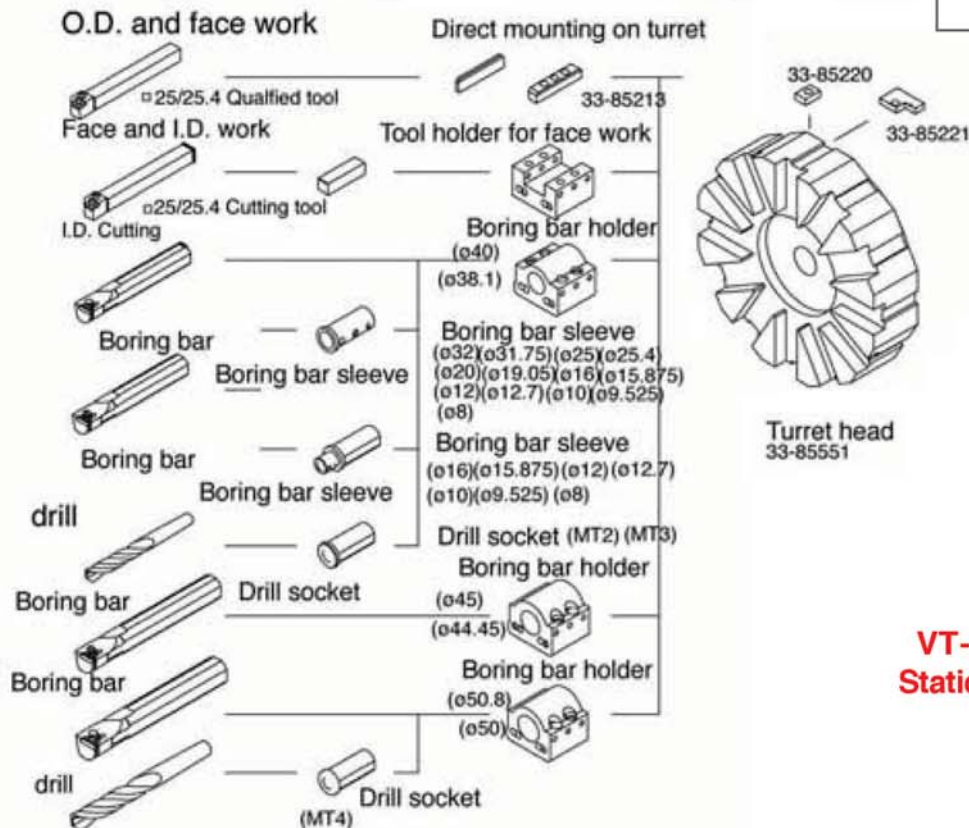

**VT-21 / VT-23
 Static Block Tool**

TURRET CAPACITY

Static Block Tool 12T

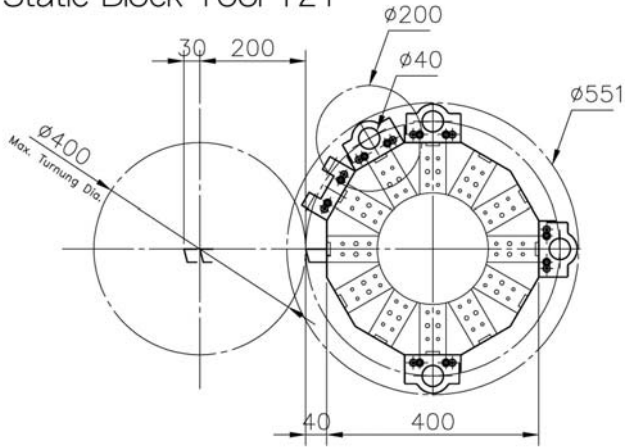

VT-21
A2-6
8''

VT-21 • Static Block Tool

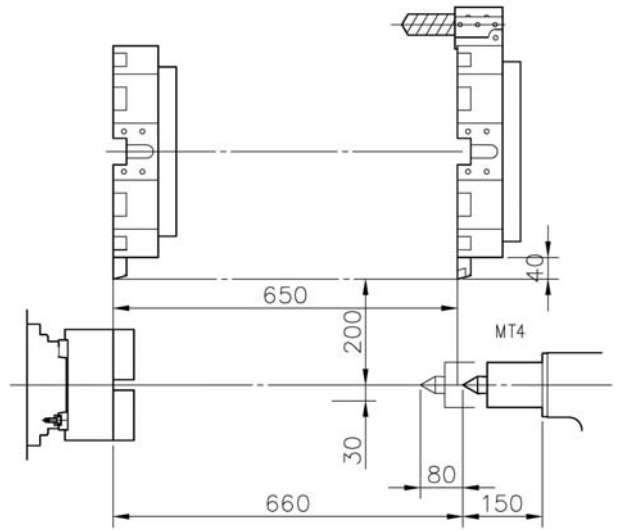

ISO A2-6

TURRET CAPACITY

Static Block Tool 12T

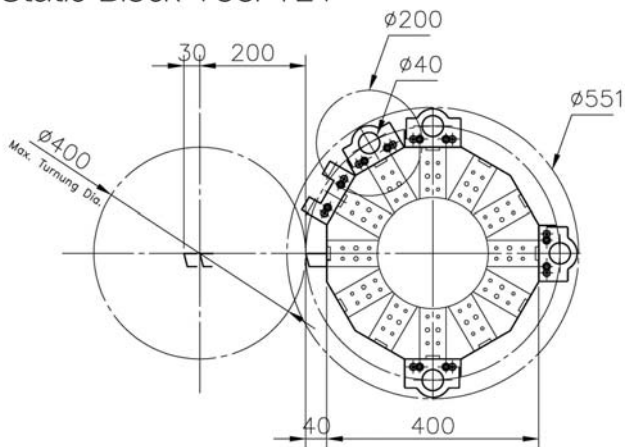

VT-23
A2-8
10''

VT-23 • Static Block Tool

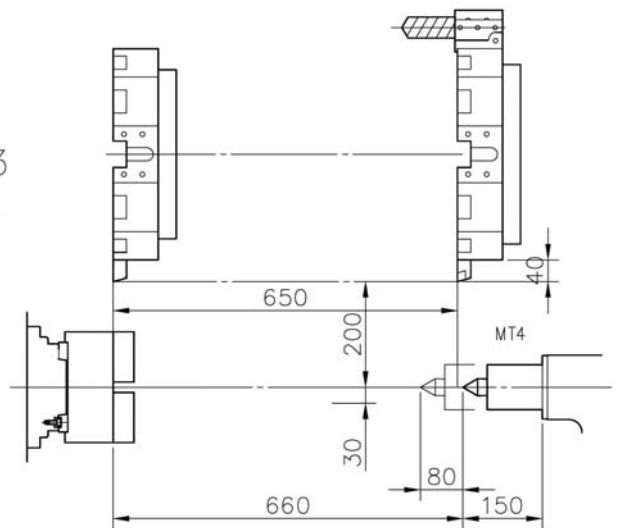

ISO A2-8

Units = mm

TURRET CAPACITY

VT-21 • Live VDI-40

SAUTER VDI40 axial live turret
0.5.436.220/12
P.C.D.370

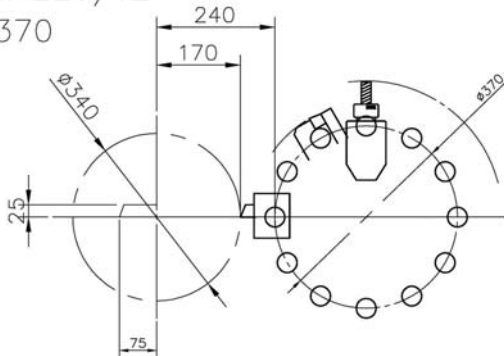

VT-21
A2-6
8''

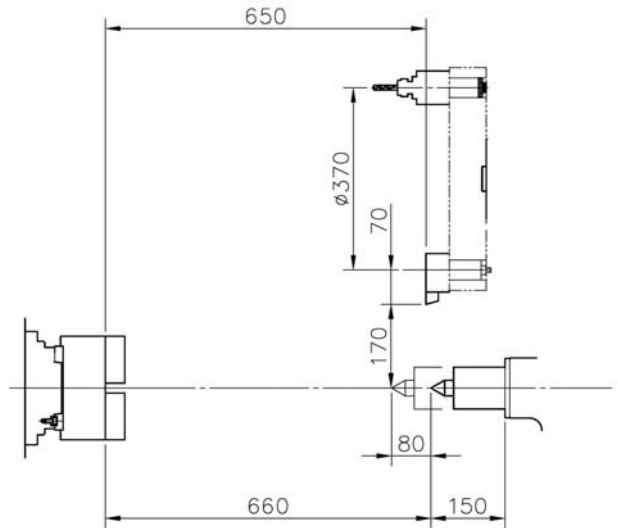

ISO A2-6

VT-23 • Live VDI-40

SAUTER VDI40 axial live turret
0.5.436.220/12
P.C.D.370

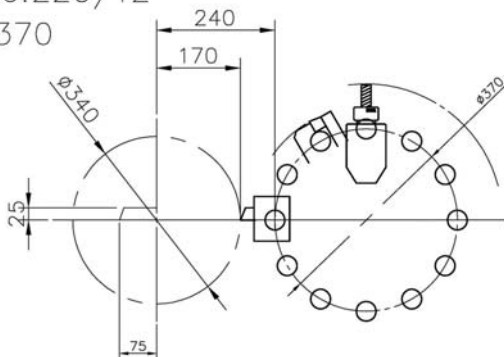

VT-23
A2-8
10''

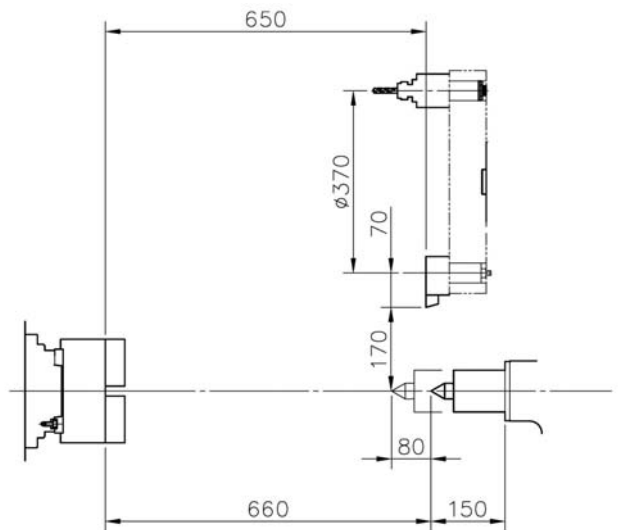

ISO A2-8

Units = inch (mm)

MACHINE DIMENSIONS

VT-21 ■ VT-23

CNC Turning Lathe
with Guarding

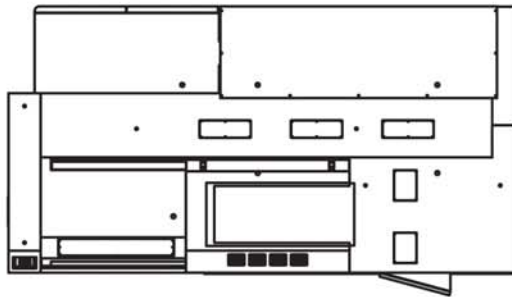

Top

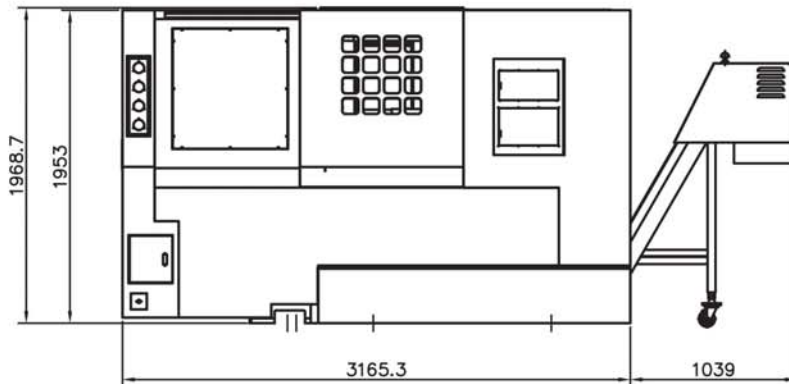
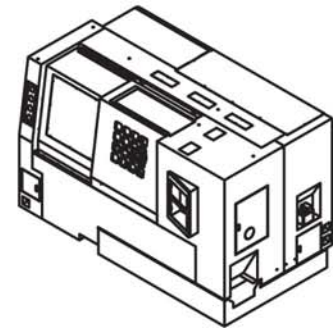

Front

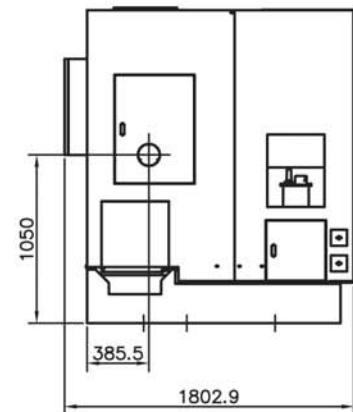

Side

Units = mm

Machine Specifications

ITEM	UNIT	VT-21	VT-23
CAPACITY			
Swing Over Z Way Cover	in (mm)	25.6 (650)	25.6 (650)
Turning Diameter Maximum	in (mm)	15.7 (400)	15.7 (400)
Swing Over Cross Slide	in (mm)	17.7 (450)	17.7 (450)
Distance Between Centers	in (mm)	25.6 (650)	25.6 (650)
Turning Length Maximum	in (mm)	25.6 (650)	25.6 (650)
Slideway Slant Angle	degree	45	45
TRAVEL			
X-Axis Travel	in (mm)	8+ 1.18 (200+30)	8+ 1.18 (200+30)
Z-Axis Travel	in (mm)	25.6 (650)	25.6 (650)
SPINDLE			
Type of Spindle Nose	ISO	A2-6	A2-8
Chuck Diameter & Type	in (mm)	8 (204)	10 (254)
Main Spindle Bearing Inner Diameter	in (mm)	4.3 (110)	4.7 (120)
Main Spindle Through Hole Diameter	in (mm)	2.4 (61)	3.2 (81)
Main Spindle Through Bar Capacity	in (mm)	2 (51)	2.6 (65)
Main Spindle Drive Motor (30 min.)	hp (kW)	20/35* (15/26*)	20/35* (15/26*)
Main Spindle Speed Range	rpm	5000	4500
TURRET			
Turret Type (Tool Number)	—	Static 12(SW=400) BMT-55/VDI40(12)	Static 12(SW=400) BMT-55/VDI40(12)
Turret Indexing Time	second	0.9	0.9
Shank Height of Square Tool	in (mm)	1 (25)	1 (25)
Shank Diameter for Boring Bar	in (mm)	1.6 (40)	1.6 (40)
FEEDRATE			
Rapid Traverse Rate X-Axis	ipm (M/min.)	787 (20)	787 (20)
Rapid Traverse Rate Z-Axis	ipm (M/min.)	945 (24)	945 (24)
Ballscrew Diameter of X-axis	in (mm)	1.26 (32)	1.26 (32)
Ballscrew Diameter of Z-axis	in (mm)	1.42 (36)	1.42 (36)
TAILSTOCK			
Tailstock Travel	in (mm)	25.9 (660)	25.9 (660)
Tailstock Spindle Diameter	in (mm)	3.34 (85)	3.34 (85)
Tailstock Spindle Travel	in (mm)	3.14 (80)	3.14 (80)
Taper Hole of Tailstock Spindle	—	MT-4	MT-4
REMARKS			
Power Requirements	V (kVA)	208 (30), 3 Phase	208 (30), 3 Phase
Coolant Pump Motor	hp(kW)	0.75 (0.6)	0.75 (0.6)
Coolant Tank Capacity	gal (L)	42(160)	42(160)
Floor Space	in (mm)	146×70.9(3710×1800)	146×70.9(3710×1800)
Machine Weight	lbs(kg)	14080 (6400)	14190 (6450)

Design and specifications are subject to change without prior notice. * Optional Accessory | ** Factory order only

Optional Accessories

- Bar Feeder IEMCA V66e (5-Feet)
- Collect Chuck (20C)
- High Pressure Coolant Through Turret 300 psi (4 GPM)
- High Pressure Coolant Through Turret 1,000 psi (8 GPM)
- Manual Tool Presetter
- Parts Catcher
- Royal Accu-Length CNC Collect Chucks A2-6 S-20, 2-Inch
- 35 hp Spindle Motor (Upgrade)

Standard Features

- Auto Lubrication System
- Block for Base
- Cooling System and Chip Tray
- Coolant Tank Guard
- Chip Conveyor
- Foot Switch for Spindle Clamp / Unclamp
- Hard Jaw (1-Set)
- Heat Exchange for Control System
- Hydraulic Adjustment System
- Leveling Pads and Screws
- Lubrication Monitoring System
- Soft Jaw (1-Set)
- Tool Box with Hand Tool
- Work Lamp



伍將機械工業股份有限公司
ALEX-TECH MACHINERY INDUSTRIAL CO., LTD.
 No. 5, Chun An Rd., Shengang District, Taichung City 429, Taiwan
 Tel:886-4-25626039 Fax:886-4-25626040
 http://www.alex-tech.com E-mail:alextech@ms24.hinet.net

ООО НПО ФОРТЭК

Украина.
 тел. - 048 7012122
 тел. - 056 7885050
 тел. - 062 3285535
 e-mail: info@fortex.in.ua
 www.fortex.in.ua

MIGHTY USA, INC.
 19706 S. Normandie Ave.
 Torrance, CA 90502
 Tel. 310.516.7478
 Fax. 310.516.0368
 E-mail. sales@mightyusa.com